

## SC12CNX.2 LBP Compressor R290 220-240V 50Hz

### General

Code number	104H8266
Approvals	EN 60335-2-34, CCC
Compressors on pallet	80

### Application

Application	LBP		
Frequency	Hz	50	60
Evaporating temperature	°C	-40 to -10	-
Voltage range	V	198 - 254	-
Max. condensing temperature continuous (short)	°C	55 (65)	-
Max. winding temperature continuous (short)	°C	125 (135)	-

### Cooling requirements

Frequency	Hz	50			60		
Application		LBP	MBP	HBP	LBP	MBP	HBP
32°C		F <sub>2</sub>	-	-	-	-	-
38°C		F <sub>2</sub>	-	-	-	-	-
43°C		F <sub>2</sub>	-	-	-	-	-
Remarks on application:							

### Motor

Motor type	CSIR		
LRA (rated after 4 sec. UL984), HST   LST	A	13.1	-
Cut in Current, HST   LST	A	13.1	-
Resistance, main   start winding (25°C)	Ω	6.8	11.5

### Design

Displacement	cm <sup>3</sup>	12.87
Oil quantity (type)	cm <sup>3</sup>	500 (polyolester)
Maximum refrigerant charge	g	150
Free gas volume in compressor	cm <sup>3</sup>	1410
Weight without electrical equipment	kg	13.1

### Dimensions

Height	mm	A	209
		B	203
		B1	183
		B2	100
Suction connector	location/I.D. mm   angle	C	8.2   37°
	material   comment		Copper   Rubber plug
Process connector	location/I.D. mm   angle	D	6.2   37°
	material   comment		Copper   Rubber plug
Discharge connector	location/I.D. mm   angle	E	6.2   37°
	material   comment		Copper   Rubber plug
Oil cooler connector	location/I.D. mm   angle	F	-
	material   comment		-
Connector tolerance	I.D. mm		±0.09
Remarks:			

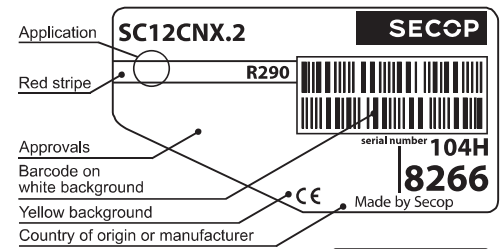

- S = Static cooling normally sufficient
- O = Oil cooling
- F<sub>1</sub> = Fan cooling 1.5 m/s  
(compressor compartment temperature equal to ambient temperature)
- F<sub>2</sub> = Fan cooling 3.0 m/s necessary
- SG = Suction gas cooling normally sufficient
- = not applicable in this area

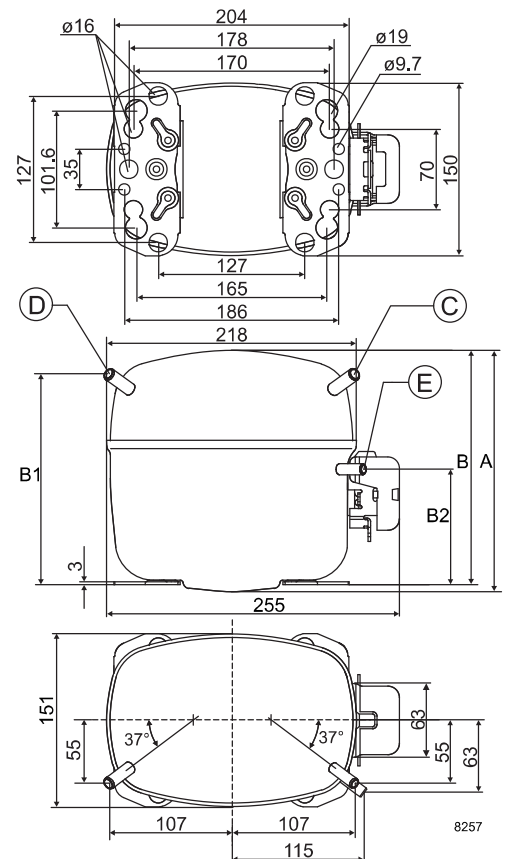

**EN 12900 Household (CECOMAF)\***  $t_c = 45^\circ\text{C}$ , 220V, 50Hz, fan cooling F<sub>2</sub>

Evap. temp. in °C	-45	-40	-35	-30	-25	-23.3	-20	-15	-10	-6.7	-5	0	5	7.2	10	15	20
Capacity in W		186	258	346	453	493	578	725	895								
Power cons. in W		257	298	339	379	393	419	460	502								
Current cons. in A		1.99	2.09	2.21	2.35	2.40	2.50	2.67	2.86								
COP in W/W		0.72	0.87	1.02	1.19	1.26	1.38	1.58	1.78								

**ASHRAE LBP\***  $t_c = 43.3^\circ\text{C}$ , 220V, 50Hz, fan cooling F<sub>2</sub>

Evap. temp. in °C	-45	-40	-35	-30	-25	-23.3	-20	-15	-10	-6.7	-5	0	5	7.2	10	15	20
Capacity in W		215	295	393	512	558	654	819	1010								
Power cons. in W		258	297	336	374	388	414	454	496								
Current cons. in A		1.99	2.08	2.20	2.33	2.38	2.48	2.65	2.83								
COP in W/W		0.83	0.99	1.17	1.37	1.44	1.58	1.80	2.04								

**EN 12900 Household (CECOMAF)**  $t_c = 55^\circ\text{C}$ , 220V, 50Hz, fan cooling F<sub>2</sub>

Evap. temp. in °C	-45	-40	-35	-30	-25	-23.3	-20	-15	-10	-6.7	-5	0	5	7.2	10	15	20
Capacity in W			184	264	359	395	470	598	744								
Power cons. in W			291	343	394	411	443	490	538								
Current cons. in A			2.07	2.21	2.37	2.43	2.55	2.75	2.96								
COP in W/W			0.63	0.77	0.91	0.96	1.06	1.22	1.38								

**ASHRAE LBP**  $t_c = 54.4^\circ\text{C}$ , 220V, 50Hz, fan cooling F<sub>2</sub>

Evap. temp. in °C	-45	-40	-35	-30	-25	-23.3	-20	-15	-10	-6.7	-5	0	5	7.2	10	15	20
Capacity in W			230	330	447	491	583	741	923								
Power cons. in W			292	344	394	410	442	489	536								
Current cons. in A			2.07	2.21	2.37	2.43	2.55	2.75	2.96								
COP in W/W			0.79	0.96	1.13	1.20	1.32	1.52	1.72								

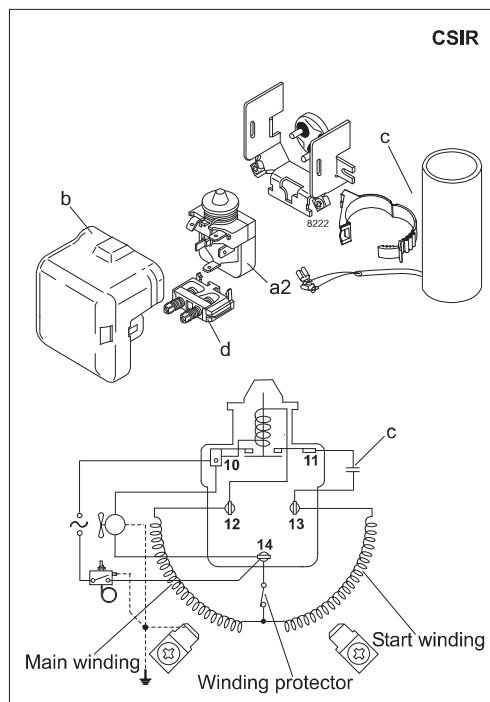

Accessories for	SC12CNX.2	Figure	Code number	Test conditions	EN 12900/ CECOMAF(*)	ASHRAE LBP(*)
PTC starting device	6.3 mm spade connectors	-	-	Condensing temperature	55°C (*45°C)	54.4 (*43.3°C)
	4.8 mm spade connectors			Ambient temperature	32°C	32°C
Starting relay	6.3 mm spade connectors	a2	117U7003	Suction gas temperature	32°C	32°C
Cover		b	103N2009	Liquid temperature	no subcooling	32°C
Start. capacitor 80 µF	6.3 mm spade connectors	c	117U5017			
Cord relief		d	103N1004			
Protection screen for PTC		-	-			
				<b>Mounting accessories</b>	<b>Code number</b>	
				Bolt joint for one comp.	Ø: 16 mm	118-1917
				Bolt joint in quantities	Ø: 16 mm	118-1918
				Snap-on in quantities	Ø: 16 mm	118-1919

Secop accepts no responsibility for possible errors in catalogs, brochures, and other printed material. Secop reserves the right to alter its products without notice. This also applies to products already on order provided that such alterations can be made without subsequential changes being necessary to specifications already agreed. All trademarks in this material are the property of the respective companies. Secop and the Secop logotype are trademarks of Secop GmbH. All rights reserved. [www.secop.com](http://www.secop.com)