

## SC12G Universal Compressor R134a 220-240V 50/60Hz

### General

Code number	104G8240
Approvals	EN 60335-2-34, UL984, CCC, EAC, KC
Compressors on pallet	80

### Application

Application	LBP/HBP	LBP/MBP
Frequency	50	60
Evaporating temperature	-35 to 15	-35 to -5
Voltage range	187 - 254	198 - 254
Max. condensing temperature continuous (short)	60 (70)	60 (70)
Max. winding temperature continuous (short)	125 (135)	125 (135)

### Cooling requirements

Frequency	Hz	50			60		
Application		LBP	MBP	HBP	LBP	MBP	HBP
32°C		F <sub>1</sub>	F <sub>2</sub>	F <sub>2</sub>	F <sub>1</sub>	F <sub>2</sub>	-
38°C		F <sub>1</sub>	F <sub>2</sub>	F <sub>2</sub>	F <sub>1</sub>	F <sub>2</sub>	-
43°C		F <sub>1</sub>	F <sub>2</sub>	F <sub>2</sub>	F <sub>1</sub>	F <sub>2</sub>	-
Remarks on application:							

### Motor

Motor type	RSIR/CSIR		
LRA (rated after 4 sec. UL984), HST   LST	A	12.6	12.4
Cut in Current, HST   LST	A	12.6	17.2
Resistance, main   start winding (25°C)	Ω	6.7	11.8

### Design

Displacement	cm <sup>3</sup>	12.87
Oil quantity (type)	cm <sup>3</sup>	500 (polyolester)
Maximum refrigerant charge	g	1300
Free gas volume in compressor	cm <sup>3</sup>	1510
Weight without electrical equipment	kg	12.6

### Dimensions

Height	mm	A	209
		B	203
		B1	183
		B2	100
Suction connector	location/I.D. mm   angle	C	8.2   37°
	material   comment	Copper   Rubber plug	
Process connector	location/I.D. mm   angle	D	6.2   37°
	material   comment	Copper   Rubber plug	
Discharge connector	location/I.D. mm   angle	E	6.2   37°
	material   comment	Copper   Rubber plug	
Oil cooler connector	location/I.D. mm   angle	F	-
	material   comment	-	
Connector tolerance	I.D. mm	±0.09	
Remarks:			

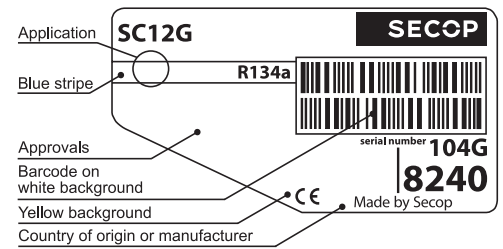

- S = Static cooling normally sufficient
- O = Oil cooling
- F<sub>1</sub> = Fan cooling 1.5 m/s (compressor compartment temperature equal to ambient temperature)
- F<sub>2</sub> = Fan cooling 3.0 m/s necessary
- SG = Suction gas cooling normally sufficient
- = not applicable in this area

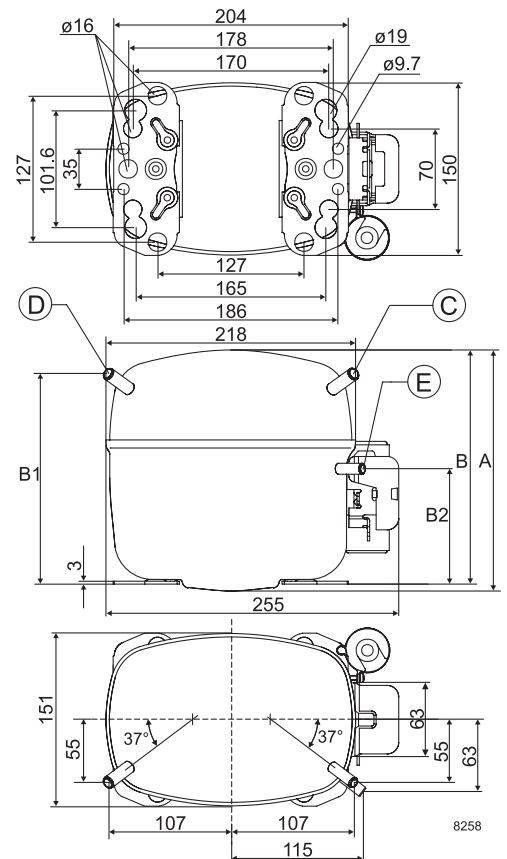

**EN 12900 Household (CECOMAF)** 220V, 50Hz, fan cooling F<sub>2</sub>

Evap. temp. in °C	-45	-40	-35	-30	-25	-23.3	-20	-15	-10	-6.7	-5	0	5	7.2	10	15	20
Capacity in W			64.6	113	175	199	252	348	464	553	603	768	960	1054	1182	1437	
Power cons. in W			148	187	227	241	268	311	355	385	400	446	493	514	541	589	
Current cons. in A			1.63	1.72	1.83	1.87	1.95	2.09	2.24	2.34	2.40	2.57	2.76	2.85	2.96	3.17	
COP in W/W			0.44	0.61	0.77	0.83	0.94	1.12	1.31	1.44	1.51	1.72	1.95	2.05	2.19	2.44	

**EN 12900 Household (CECOMAF)** 220V, 60Hz, fan cooling F<sub>2</sub>

Evap. temp. in °C	-45	-40	-35	-30	-25	-23.3	-20	-15	-10	-6.7	-5	0	5	7.2	10	15	20
Capacity in W			74.2	131	203	232	294	406	542	646	704						
Power cons. in W			172	218	265	281	313	363	415	449	468						
Current cons. in A			1.79	1.89	2.01	2.06	2.15	2.30	2.46	2.57	2.64						
COP in W/W			0.43	0.60	0.77	0.83	0.94	1.12	1.31	1.44	1.51						

**ASHRAE LBP** 220V, 50Hz, fan cooling F<sub>2</sub>

Evap. temp. in °C	-45	-40	-35	-30	-25	-23.3	-20	-15	-10	-6.7	-5	0	5	7.2	10	15	20
Capacity in W			79.6	140	216	246	312	430	574	684	746	951	1191	1308	1469	1790	
Power cons. in W			148	187	227	241	268	311	355	385	400	446	493	514	541	589	
Current cons. in A			1.63	1.72	1.83	1.87	1.95	2.09	2.24	2.34	2.40	2.57	2.76	2.85	2.96	3.17	
COP in W/W			0.54	0.75	0.95	1.02	1.16	1.38	1.62	1.78	1.87	2.13	2.42	2.55	2.72	3.04	

**ASHRAE LBP** 220V, 60Hz, fan cooling F<sub>2</sub>

Evap. temp. in °C	-45	-40	-35	-30	-25	-23.3	-20	-15	-10	-6.7	-5	0	5	7.2	10	15	20
Capacity in W			91.5	162	251	286	363	501	670	799	872						
Power cons. in W			172	218	265	281	313	363	415	449	468						
Current cons. in A			1.79	1.89	2.01	2.06	2.15	2.30	2.46	2.57	2.64						
COP in W/W			0.53	0.74	0.95	1.02	1.16	1.38	1.61	1.78	1.86						

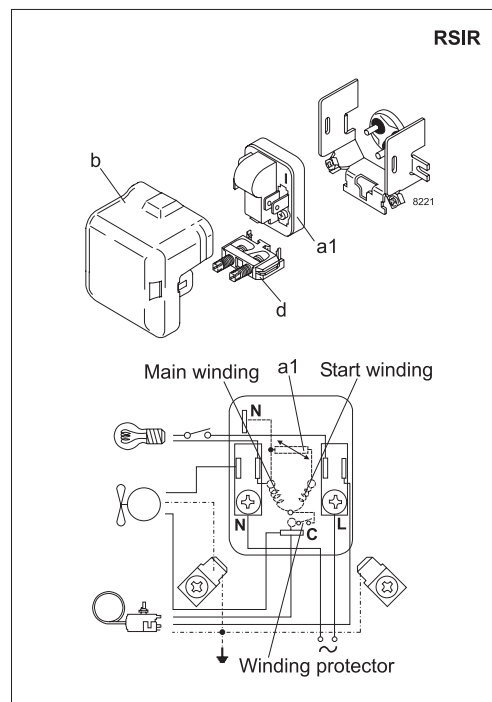
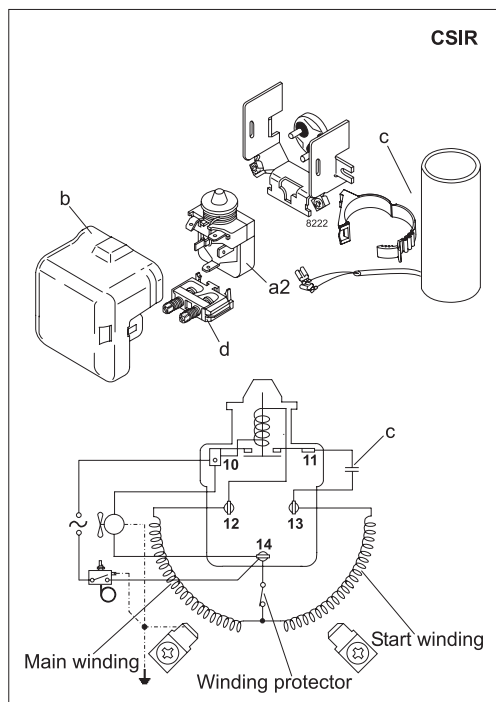

Accessories for	SC12G	Figure	Code number
PTC starting device	6.3 mm spade connectors	a1	103N0011
	4.8 mm spade connectors		-
Starting relay	6.3 mm spade connectors	a2	117U6003
Cover		b	103N2009
Start. capacitor 80 µF	6.3 mm spade connectors	c	117U5017
Cord relief		d	103N1004
Protection screen for PTC		g	-

Test conditions	EN 12900/CECOMAF	ASHRAE LBP
Condensing temperature	55°C	55°C
Ambient temperature	32°C	32°C
Suction gas temperature	32°C	32°C
Liquid temperature	55°C	32°C

Mounting accessories		Code number
Bolt joint for one comp.	Ø: 16 mm	118-1917
Bolt joint in quantities	Ø: 16 mm	118-1918
Snap-on in quantities	Ø: 16 mm	118-1919

Nidec GA Compressors accepts no responsibility for possible errors in catalogs, brochures, and other printed material. Nidec GA Compressors reserves the right to alter its products without notice. This also applies to products already on order provided that such alterations can be made without consequential changes being necessary to specifications already agreed. All trademarks in this material are the property of the respective companies. Secop and the Secop logotype are trademarks of Nidec Global Appliance Germany GmbH. All rights reserved. [www.secop.com](http://www.secop.com)