

SC10CL LBP/MBP Compressor R404A/R507 220-240V 50Hz

General

Code number	104L2523
Approvals	EN 60335-2-34, CCC, EAC
Compressors on pallet	80

Application

Application	LBP/MBP		
Frequency	Hz	50	60
Evaporating temperature	°C	-35 to -5	-
Voltage range	V	198 - 254	-
Max. condensing temperature continuous (short)	°C	55 (60)	-
Max. winding temperature continuous (short)	°C	125 (135)	-

Cooling requirements

Frequency	Hz	50			60		
Application		LBP	MBP	HBP	LBP	MBP	HBP
32°C		F ₂	F ₂	-	-	-	-
38°C		F ₂	F ₂	-	-	-	-
43°C		-	-	-	-	-	-
Remarks on application:							

Motor

Motor type	CSIR		
LRA (rated after 4 sec. UL984), HST LST	A	12.6	-
Cut in Current, HST LST	A	12.6	-
Resistance, main start winding (25°C)	Ω	6.7	11.8

Design

Displacement	cm ³	10.29
Oil quantity (type)	cm ³	500 (polyolester)
Maximum refrigerant charge	g	1300
Free gas volume in compressor	cm ³	1460
Weight without electrical equipment	kg	13.1

Dimensions

Height	mm	A	209
		B	203
		B1	183
		B2	100
Suction connector	location/I.D. mm angle	C	8.2 37°
	material comment		Copper Rubber plug
Process connector	location/I.D. mm angle	D	6.2 37°
	material comment		Copper Rubber plug
Discharge connector	location/I.D. mm angle	E	6.2 37°
	material comment		Copper Rubber plug
Oil cooler connector	location/I.D. mm angle	F	-
	material comment		-
Connector tolerance	I.D. mm		±0.09
Remarks:			

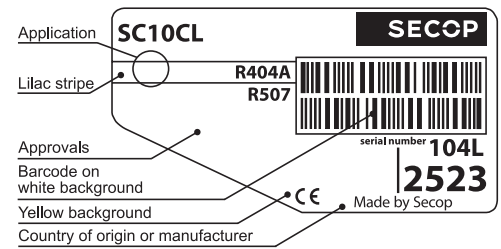

- S = Static cooling normally sufficient
- O = Oil cooling
- F₁ = Fan cooling 1.5 m/s
(compressor compartment temperature equal to ambient temperature)
- F₂ = Fan cooling 3.0 m/s necessary
- SG = Suction gas cooling normally sufficient
- = not applicable in this area

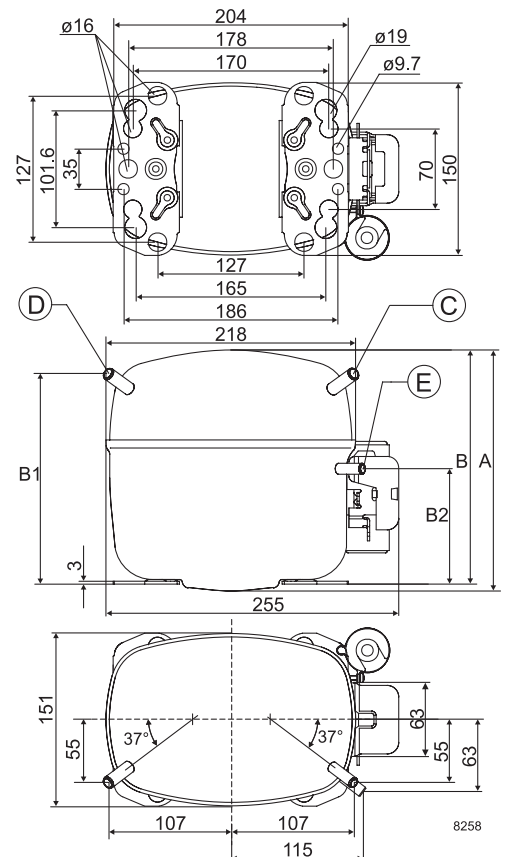

EN 12900 Household (CECOMAF)

 220V, 50Hz, fan cooling F₂

Evap. temp. in °C	-45	-40	-35	-30	-25	-23.3	-20	-15	-10	-6.7	-5	0	5	7.2	10	15	20
Capacity in W			168	258	365	405	489	634	800	923	991						
Power cons. in W			243	294	350	370	410	471	530	566	584						
Current cons. in A			1.91	2.05	2.22	2.27	2.39	2.59	2.81	2.96	3.04						
COP in W/W			0.69	0.88	1.04	1.09	1.19	1.35	1.51	1.63	1.70						

ASHRAE LBP*

 220V, 50Hz, fan cooling F₂

Evap. temp. in °C	-45	-40	-35	-30	-25	-23.3	-20	-15	-10	-6.7	-5	0	5	7.2	10	15	20
Capacity in W			195	300	424	470	569	737	932	1071	1154						
Power cons. in W			243	294	350	370	410	471	530	566	584						
Current cons. in A			1.91	2.05	2.22	2.27	2.39	2.59	2.81	2.96	3.04						
COP in W/W			0.80	1.02	1.21	1.27	1.39	1.57	1.76	1.89	1.98						

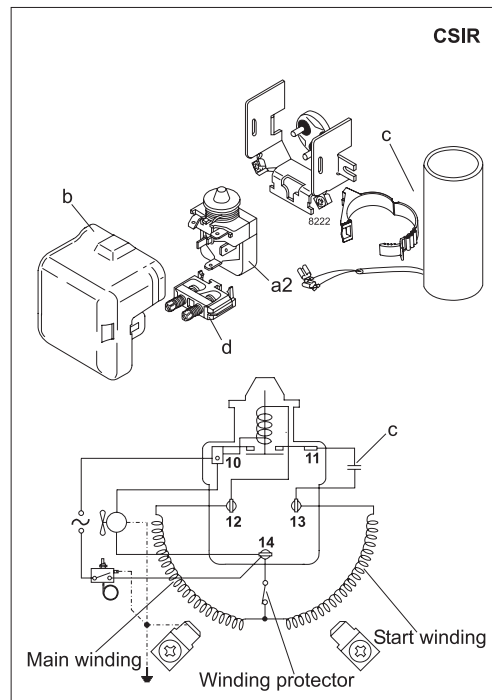

Accessories for	SC10CL	Figure	Code number	Test conditions	EN 12900/CECOMAF	ASHRAE LBP*
PTC starting device	6.3 mm spade connectors	a1	–	Condensing temperature	45°C	45°C
	4.8 mm spade connectors		–	Ambient temperature	32°C	32°C
Starting relay	6.3 mm spade connectors	a2	117U6003	Suction gas temperature	32°C	32°C
Cover		b	103N2009	Liquid temperature	no subcooling	32°C
Start. capacitor 80 µF	6.3 mm spade connectors	c	117U5017			
Cord relief		d	103N1004			
Protection screen for PTC		g	–			
				Mounting accessories		Code number
				Bolt joint for one comp.	Ø: 16 mm	118-1917
				Bolt joint in quantities	Ø: 16 mm	118-1918
				Snap-on in quantities	Ø: 16 mm	118-1919

Nidec GA Compressors accepts no responsibility for possible errors in catalogs, brochures, and other printed material. Nidec GA Compressors reserves the right to alter its products without notice. This also applies to products already on order provided that such alterations can be made without subsequential changes being necessary to specifications already agreed. All trademarks in this material are the property of the respective companies. Secop and the Secop logotype are trademarks of Nidec Global Appliance Germany GmbH. All rights reserved. www.secop.com