

EN 12900 Household (CECOMAF) 220V, 50Hz, fan cooling F₂

Evap. temp. in °C	-45	-40	-35	-30	-25	-23.3	-20	-15	-10	-6.7	-5	0	5	7.2	10	15	20
Capacity in W				84.9	123	138	171	228	298	351	381	478	592	647	722		
Power cons. in W				127	151	159	176	203	231	251	261	291	321	335	352		
Current cons. in A				1.16	1.22	1.25	1.30	1.38	1.47	1.53	1.56	1.67	1.78	1.83	1.90		
COP in W/W				0.67	0.82	0.87	0.97	1.12	1.29	1.40	1.46	1.65	1.84	1.93	2.05		

EN 12900 Household (CECOMAF) 220V, 60Hz, fan cooling F₂

Evap. temp. in °C	-45	-40	-35	-30	-25	-23.3	-20	-15	-10	-6.7	-5	0	5	7.2	10	15	20
Capacity in W				92.3	138	156	195	263	345								
Power cons. in W				134	164	174	197	233	273								
Current cons. in A				1.02	1.12	1.16	1.24	1.37	1.53								
COP in W/W				0.69	0.85	0.90	0.99	1.13	1.26								

ASHRAE LBP 220V, 50Hz, fan cooling F₂

Evap. temp. in °C	-45	-40	-35	-30	-25	-23.3	-20	-15	-10	-6.7	-5	0	5	7.2	10	15	20
Capacity in W				105	152	171	211	282	368	434	471	592	734	803	898		
Power cons. in W				127	151	159	176	203	231	251	261	291	321	335	352		
Current cons. in A				1.16	1.22	1.25	1.30	1.38	1.47	1.53	1.56	1.67	1.78	1.83	1.90		
COP in W/W				0.83	1.01	1.07	1.19	1.39	1.59	1.73	1.81	2.04	2.29	2.40	2.55		

ASHRAE LBP 220V, 60Hz, fan cooling F₂

Evap. temp. in °C	-45	-40	-35	-30	-25	-23.3	-20	-15	-10	-6.7	-5	0	5	7.2	10	15	20
Capacity in W				114	171	193	241	325	426								
Power cons. in W				134	164	174	197	233	273								
Current cons. in A				1.02	1.12	1.16	1.24	1.37	1.53								
COP in W/W				0.85	1.04	1.11	1.22	1.39	1.56								

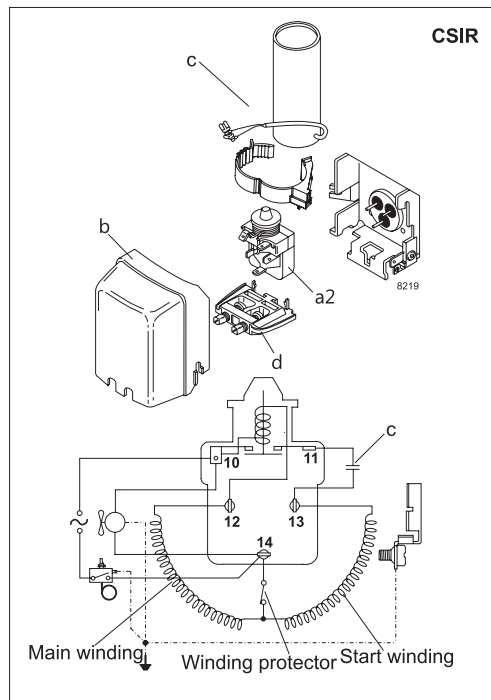
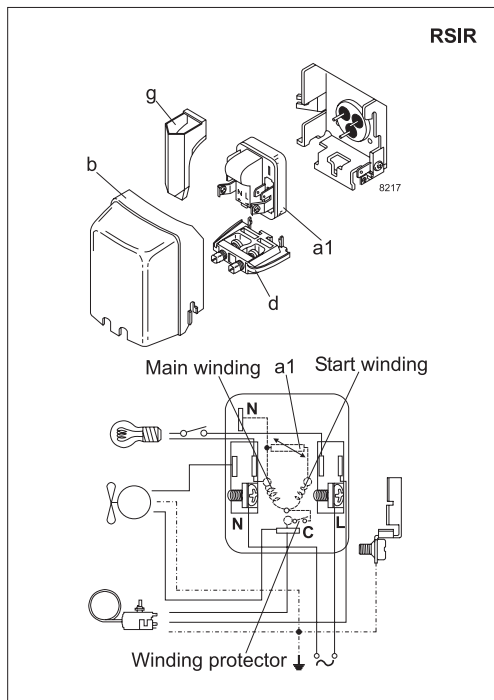

Accessories for	FR8.5G	Figure	Code number
PTC starting device	6.3 mm spade connectors	a1	103N0011
	4.8 mm spade connectors		103N0018
Starting relay	6.3 mm spade connectors	a2	117U6015
Start. capacitor 80 µF	6.3 mm spade connectors	c	117U5015
Cover		b	103N2010
Cord relief		d	103N1010
Protection screen for PTC		g	103N0476

Test conditions	EN 12900/CECOMAF	ASHRAE
Condensing temperature	55°C	55°C
Ambient temperature	32°C	32°C
Suction gas temperature	32°C	32°C
Liquid temperature	55°C	32°C

Mounting accessories		Code number
Bolt joint for one comp.	Ø: 16 mm	118-1917
Bolt joint in quantities	Ø: 16 mm	118-1918
Snap-on in quantities	Ø: 16 mm	118-1919

Nidec GA Compressors accepts no responsibility for possible errors in catalogs, brochures, and other printed material. Nidec GA Compressors reserves the right to alter its products without notice. This also applies to products already on order provided that such alterations can be made without subsequential changes being necessary to specifications already agreed. All trademarks in this material are the property of the respective companies. Secop and the Secop logotype are trademarks of Nidec Global Appliance Germany GmbH. All rights reserved. www.secop.com